

A Miniaturized Quadrifilar Helix Antenna for Handheld UHF RFID Reader Applications

Chen-An Ou and Chien-Wen Chiu

Department of Electronic Engineering, National Ilan University, Ilan 260, Taiwan

Abstract — The paper presents a printed quadrifilar helix antenna (QHA) fed by a power divider with 0° , 90° , 180° , 270° phases and equal amplitudes to excite circularly polarized waves for UHF RFID applications. The proposed antenna features broadband and compact size due to a small ground. The impedance bandwidth for $|S_{11}| < 10$ dB ranges from 700 to 987 MHz (31% at 910 MHz). The 3-dB axial ratio bandwidth can cover 800-1000 MHz and the measured maximum gain is about 5.8 dBi at 955 MHz. The miniaturized CP antenna can be embedded to a handheld UHF RFID reader.

Index Terms — Quadrifilar helix antenna (QHA), power splitter, RF identification (RFID), ultra high frequency (UHF).

I. INTRODUCTION

In recent years, RFID technology becomes more and more mature. The transceiver antenna of a reader can be a circularly polarized antenna or linearly polarized antenna. A circularly polarized (CP) antenna is more promising for UHF RFID application. Since tag placement has no determined orientation, the tag antenna with linearly polarization may not receive signal from the linearly polarized reader. A reader antenna must be high gain and circularly polarized for longer read ranges. To achieve high gain, most of reader antennas always employ planar patches which are relatively big. Compact antennas are necessary for handheld RFID reader design. However, its bandwidth is still not enough [1].

If antenna size is a main consideration, resonance-typed QHA is the best choice for the handheld RFID reader. Resonant quadrifilar helix antenna was proposed in 1969 [2]. In 1970, Adams *et al.* used four-quadrature phases and equal-amplitudes feeding system to feed QHA by experiment [3] and also performed numerical computation to analyze the QHA in 1974 [4]. In 1999, some scholars proposed central dielectric rods to reduce QHA size [5]. In 2009, a miniaturized but narrow-band QHA for GPS reception [6] was proposed. Recently, meander helix arms were employed to reduce QHA size [7], [8].

This paper integrated a power-splitter feeding system with quadrature phases and equal amplitude into a resonant quadrifilar helix antenna. The power splitter consists of an 180° lumped-element power splitter and two lumped-element 3 dB quadrature hybrid couplers. The printed resonant QHA is composed of two resonant bifilar helix antennas (BHAs). The electrical length of each BHA is about one wavelength. In order to excite circularly polarized wave, the printed resonant QHA is fed by 0° , 90° , 180° , 270° input signals which are generated by lumped-element power splitters. The proposed antenna can achieve compact size, broadband and wider axial ratio bandwidth.

II. PHASE SHIFTER DESIGN

A. 3 dB Quadrature Hybrid Coupler

Refer to literature [9], a 3 dB quadrature hybrid coupler with high-pass and low-pass lumped elements was designed and implemented as a 90° power divider. This paper used a high frequency circuit simulator, Advanced Design System (ADS), to simulate the designed circuit. Fig. 1 shows its topology. Port 1 is assumed as input terminal, port 4 is isolation terminal, and port 2 and port 3 are output terminals. All of the capacitors and inductors model were downloaded from Murata library [10]. If the values of lumped elements L and C were chosen as 5.6 nH and 3 pF, respectively, simulated results depicts that port 2 and port 3 have a half power and 90° phase difference, and port 4 has good isolation.

B. 180° Power Splitter

Parisi used high-pass and low-pass lumped elements to design an 180° power splitter [11]. Refer to Parisi's topology, Fig. 2 shows the circuit schematic of a 180° Power Splitter. Port 1 is assumed as input terminal, port1 is isolation terminal, and port 3 and port 4 are output terminals. By using the ADS simulation tool, the values of lumped elements L_1 , L_2 , C_1 , C_2 are about 1 pF, 2 pF, 5.6 nH, and 12 nH, respectively. The hybrid circuit generates a half power and 180° phase difference in the two output terminals, and port 1 had excellent isolation.

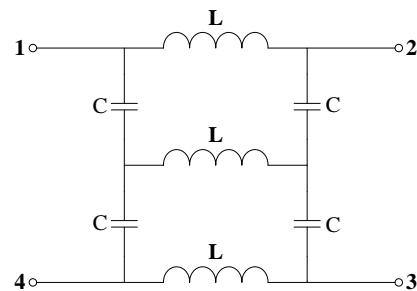

Fig. 1 Quadrature hybrid coupler with high/low pass elements.

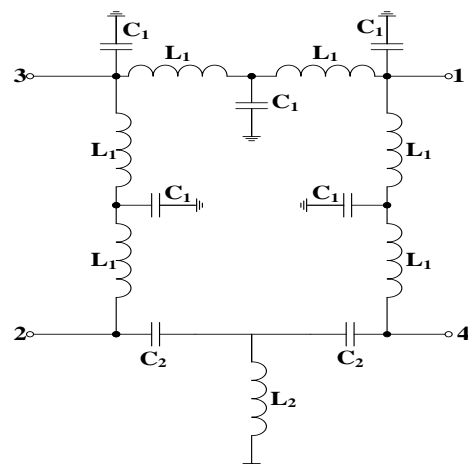

Fig. 2 180° power splitter with high/low pass lumped elements.

C. Quadrature Phase Power Splitter

The whole feeding network is constructed from an 180° power splitter combined with two quadrature hybrid couplers, which are implemented on a 1.6-mm-thick FR4 substrate. The ANSYS EM simulation software, HFSS, was performed to simulate the whole circuit. Fig. 3 shows the layout of the constructed feeding network. In this figure, port 5 is an input terminal and other ports are output terminals. The combined power splitter could generate output phases with 0° , 90° , 180° and 270° and equal output powers in the four output ports.

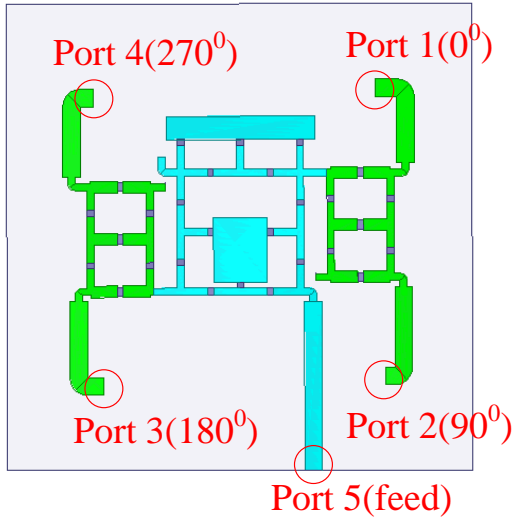

Fig. 3 The four phases' power splitter layout.

III. ANTENNA DESIGN

Fig. 4 presents the geometry configuration of the proposed PQHA. To exhibit circular polarization, the resonant PQHA is composed of four equally parallel helices wrapped around a cylinder which is foam. A metal ring formed a shorted circuit connected to the four helix arms on the top. The arm length of each helix and part of the shorted ring is about half a wavelength at 910 MHz. The optimum pitch angle of the helix is about 32.5° . The PQHA is fed at each port by phase quadrature signals on the back plane of a FR4 substrate. The input quadrature signals come from the feeding system mentioned in the previous section. The size of the ground plane printed on the FR4 substrate is $80 \times 80 \text{ cm}^2$. The metal strips of the PQHA are manufactured on a thin substrate which is a flexible printed circuit (FPC) and stuck on the cylinder Styrofoam. The FPC substrate is a polyimide (PI) which depth is 25 μm , and loss tangent is 0.008.

A model of the PQHA was created in Ansys HFSS and four port sources are fed to the QHA to perform simulation. Then, we translated the S-parameters into the input impedance from below formula [12]

$$Z_{in} = \frac{1 + S_{11} + jS_{12} - S_{13} - jS_{14}}{1 - S_{11} - jS_{12} + S_{13} + jS_{14}} Z_0,$$

where Z_{in} is the input impedance of QHA, Z_0 is the impedance of the measurement system (typically 50Ω). To let the antenna achieve resonance at 910 MHz, H_1 , H_2 and D were tuned in HFSS. After adjusting impedances, the feeding system in section II is

mounted on the QHA bottom. The resonant PQHA can generate right-hand circular polarization (RHCP) or left-hand circular polarization (LHCP) waves. In this paper, the proposed antenna belongs to LHCP according to the input phase sequence. Fig. 4 shows the designed antenna system which the height of H_1 measures 79 mm, the radius measures 35 mm, and the FR4 substrate for the feeding system measures $80 \times 80 \times 1.6 \text{ mm}^3$.

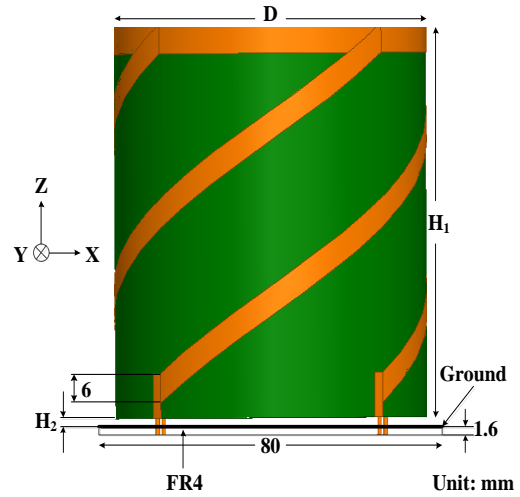
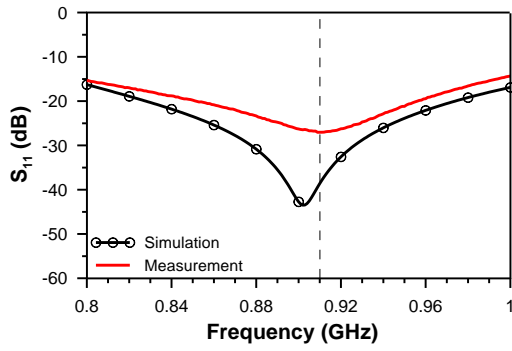

Fig. 4 Geometric configuration of the PQHA. H_1 , H_2 and D are 79 mm, 2 mm and 70 mm, respectively.

IV. RESULT AND DISCUSSION

Fig. 5 shows simulation results of the 3 dB quadrature hybrid coupler by ADS. The simulation results compared with the measured data show a good agreement. The quadrature coupler really generates a 90° phase difference at the output terminals. Fig. 6 shows simulation results of the 180° power splitter. Also shown in the figure for comparisons are measured data. The comparison shows good agreement between the simulated and measured results. It confirms the validity of the design circuit. Fig. 7 shows input impedance, insertion loss and phases of the integrated power splitter. The study finds that the power splitter covers the UHF RFID bands used in the whole market. The integrated feeding system can excite quadrature input signals connected to the proposed PQHA.

Fig. 8 shows the return loss of the antenna system which integrates the PQHA and the feeding system. The measured bandwidth of the proposed antenna ranges from 700 to 987 MHz, which is sufficient for RFID applications. The axial ratio, gain and radiation pattern were measured at the anechoic chamber in National Taiwan University of Science and Technology (NTUST). Fig. 9 shows the axial ratio of the PQHA, where the operating bandwidth covers 800-1000 MHz. The proposed antenna is a purely circularly polarized antenna since it is fed by the quadrature input signals. Fig. 10 shows the antenna gain of the proposed PQHA. Although the ground plane is shrunk, the proposed antenna maximum measured gain still has 5.8 dBic at 955 MHz. The measured directivity gain is about 4.73 dBic at 910 MHz in $+z$ axis ($\theta = 0^\circ$). Fig. 11 and 12 shows radiation patterns on the XZ and YZ plane, respectively. The 3-dB beamwidth is about 168° . The shapes of hemispherical pattern for RHCP and LHCP depict that the antenna generates pure circularly polarized waves. Fig. 13 presents the constructed PQHA antenna system.



(a)

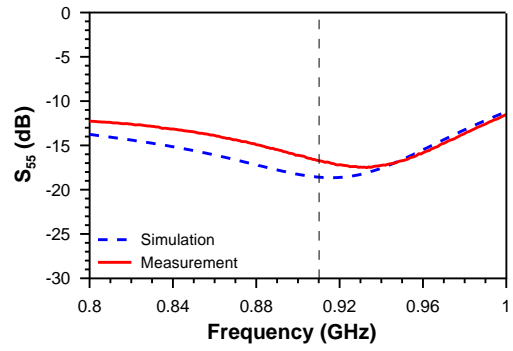

(a)

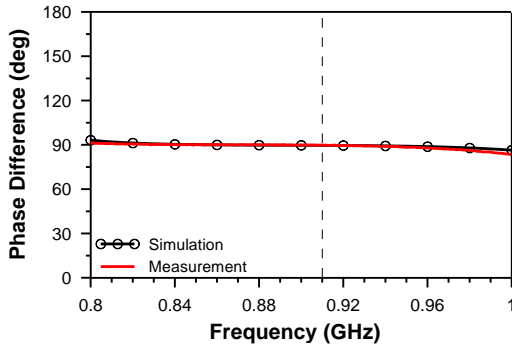

(b)

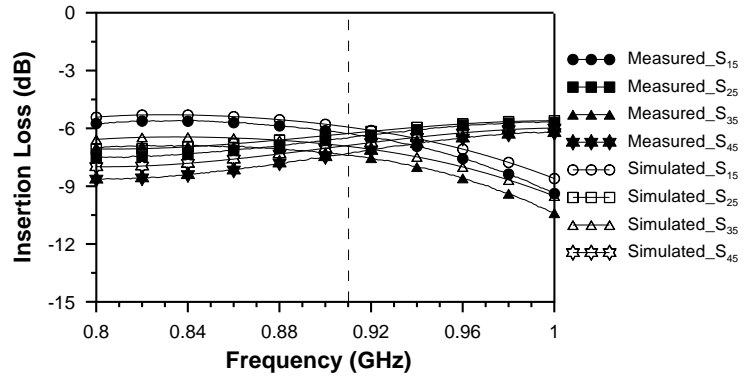

(b)

Fig. 5 Simulated and measured results of the 3 dB quadrature hybrid coupler, (a) reflection coefficient, (b) Phase difference at the outputs.

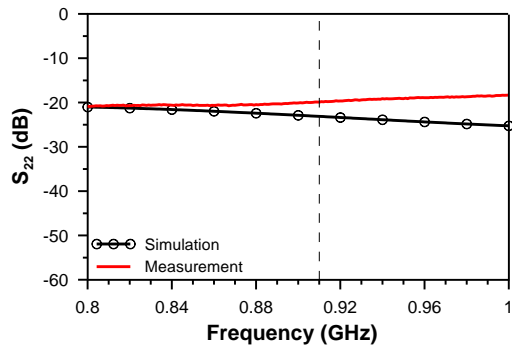

(a)

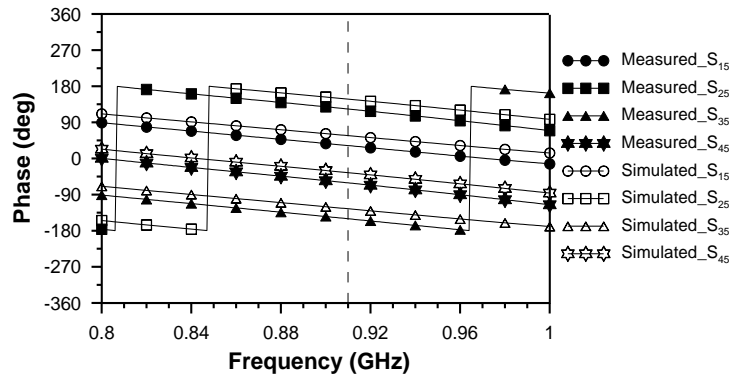

(c)

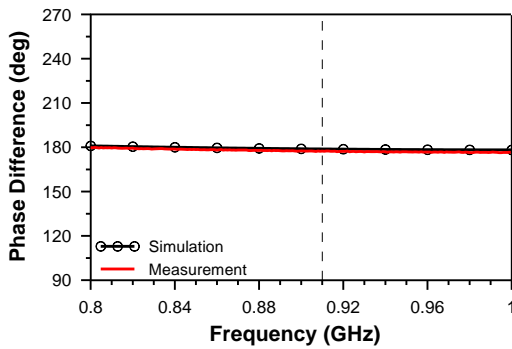

(b)

Fig. 7 Simulated and measured results of the integrated feeding system, (a) reflection coefficient and (b) phase difference at the output ports.

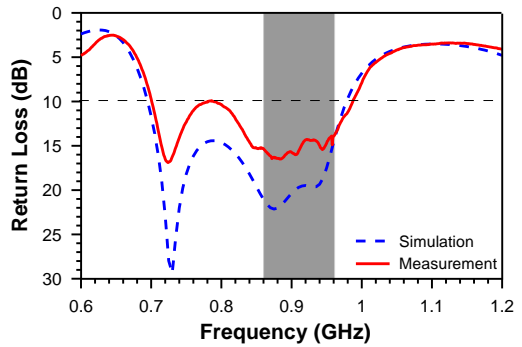

Fig. 8 Measured and simulated return loss of the entire system.

Fig. 6 Simulated and measured results of the 180° power splitter, (a) reflection coefficient and (b) phase difference at the outputs.

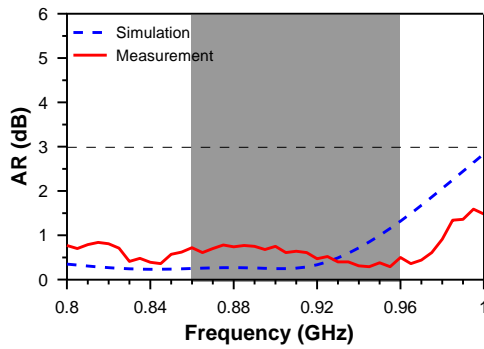

Fig. 9 Measured and simulated axial ratio of the antenna system.

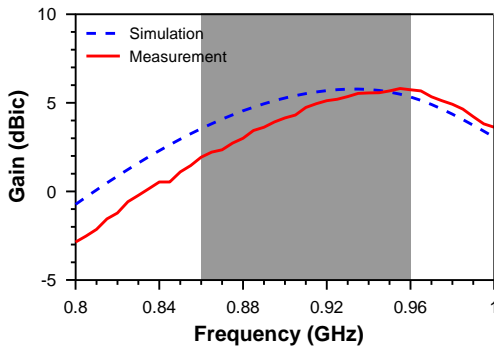

Fig. 10 Measured and simulated gain of the antenna system.

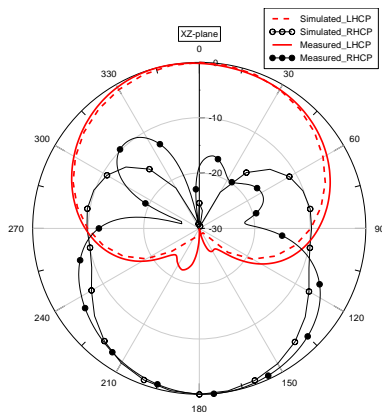

Fig. 11 Radiation pattern on the XZ plane at 910 MHz.

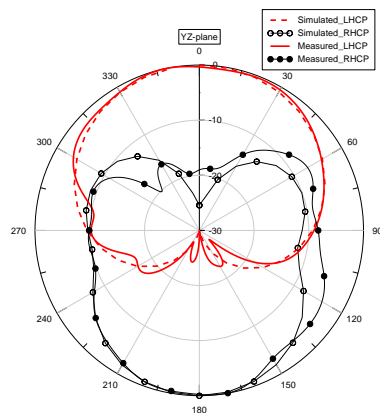

Fig. 12 Radiation pattern on the YZ plane at 910 MHz.

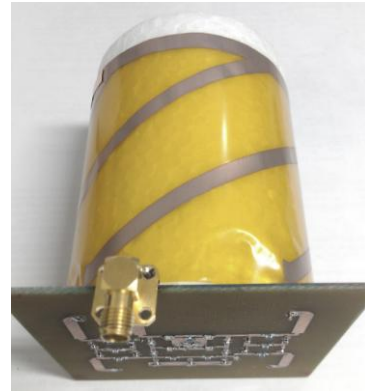

Fig. 13 Photograph of the manufactured PQHA.

CONCLUSION

The conference paper proposed a compact PQHA which is fed by quadrature input signals. Two 3 dB quadrature hybrid couplers and one 180° power splitter are successfully integrated to form the whole feeding system. The miniaturized PQHA has excellent impedance bandwidth and axial ratio bandwidth which can cover the global UHF RFID band (860-960 MHz). Also, it has a high gain although the feeding system used lumped-elements on a PCB board. The proposed antenna is promising and suitable for the handheld UHF RFID reader applications.

REFERENCES

- [1] P. V. Nikitin and K. V. S. Rao, "Helical Antenna for Handheld UHF RFID Reader," *IEEE International Conference on RFID 2010*, April 2010, pp. 166-173.
- [2] C. C. Kilgus, "Resonant Quadrifilar Helix," *IEEE Transactions on Antennas and Propagation*, Vol. 16, No. 5, pp. 349-351, May 1969.
- [3] A. T. Adams, "Optimization of the Quadrifilar Helix Antenna," *IEEE Transactions on Antennas and Propagation*, Vol. 18, No. 9, pp. 547-548, Nov. 1970.
- [4] A. T. Adams, R. K. Greenough, R. F. Wallenberg, A. Mendelovicz, and C. Lumjiak, "The Quadrifilar Helix Antenna," *IEEE Transactions on Antennas and Propagation*, Vol. 22, No. 2, pp. 173-178, March 1974.
- [5] B. Desplanchet, A. Sharaiha and C. Terret, "Parametrical Study of Printed Quadrifilar Helical Antenna," *Microwave and Optical Technology Letters*, Vol. 20, NO. 4, Feb. 1999.
- [6] Y. S. Wang and S. J. Chung, "A Miniature Quadrifilar Helix Antenna for Global Positioning Satellite Reception," *IEEE Transactions on Antennas and Propagation*, Vol. 57, No. 12, pp. 3746-3751, Dec. 2009.
- [7] A. Takacs, N. J. G. Fonseca, and H. Aubert, "Height Reduction of the Axial-Mode Open-Ended Quadrifilar Helical Antenna," *IEEE Antennas and Wireless Propagation Letters*, Vol. 9, pp.942-945, 2010.
- [8] J. Rabemanantsoa and A. Sharaiha, "Size Reduced Multi-Band Printed Quadrifilar Helical Antenna," *IEEE Transactions on Antennas and Propagation*, Vol.59, No. 9, pp.3138-3143, Sept. 2011.
- [9] J. A. Hou and Y. H. Wang, "A Compact Quadrature Hybrid Based on High-Pass and Low-Pass Lumped Elements," *IEEE Microwave and Wireless Component Letters*, Vol. 17, No. 8, Aug. 2007.
- [10] Murata Manufacturing Co. [Online]. Available: <http://www.murata.com>.
- [11] S. J. Parisi, "180° Lumped Element Hybrid," *IEEE MTT-S International Microwave Symposium Digest*, Vol.3, June. 1989, pp. 1243-1246.
- [12] O. P. M. Pekonen, V. Santomaa, K. Kiesi, M. E. Ermutlu, and K. Wilksa, "Measuring the Input Impedance of a Quadrifilar Helix Antenna," *Microwave and Optical Technology Letters*, Vol. 17, No. 2, Feb. 1998.