

Design and Implementation of a Standalone Potentiostat for Electrochemical Biosensors

Chun-Yueh Huang^{1*}, Wen-Chih Li¹ and Hung-Yin Lin²

¹Department of Electrical Engineering, National University of Tainan

²Department of Chemical and Materials Engineering, National University of Kaohsiung

Abstract-- In this paper, we design and implement a low-cost and standalone potentiostat for the signal processing of electrochemical biosensors, and further exert the vanillylmandelic acid biosensing to verify its performance. In the experiment, we adopt a personal digital assistant (PDA), rather than using a personal computer (PC), to set the experimental parameters to the potentiostat through Bluetooth wireless communication. The biosensor's measurement is controlled by a mixed-signal microprocessor, and the measured data are stored in a memory card. The power supply of the standalone potentiostat is provided by a USB charger. When the experiment is finished, the data stored in memory card can be retrieved and analyzed by a computer. Our experimental results show that the proposed potentiostat has the merits of good accuracy, low cost, low power consumption, and high portability.

Index Terms-- potentiostat, electrochemical biosensors, signal processing circuit

I. INTRODUCTION

Electrochemical biosensors, commonly applied in DNA identification, neural recording, glucose determination, or pH variation detection, show the detected data by potential or current [1-4]. They are more economical and convenient than optical biosensors, because they do not need expensive optical set-ups, such as CCD cameras and lenses. Considering the economical and convenient features, we adopt the electrochemical approach to design a vanillylmandelic acid (VMA) biosensor to detect the patients' VMA concentration in urine. The VMA biosensor needs a potentiostat to maintain electrochemical stability and to convert the biosensor's output into an analog signal. Without a potentiostat, the electrochemical VMA biosensor cannot work.

Up to the present, two sorts of potentiostats have been frequently used: one is the commercial potentiostat designed for research in laboratory, and the other is the specific potentiostat developed for a particular sensor. The former is sophisticated, high accuracy (the ADC resolution is higher than 14-bit), expensive (the cost is higher than ten thousand US dollars), and non-portable, and the latter is simple, low-cost, and portable. In the light of low cost and portability, the latter seems to be more popular for researchers to study. Turner presented a basic CMOS integrated potentiostat [5],

Kakerow presented a monolithic potentiostat [6], and Bandyopadhyay proposed a multi-channel potentiostat designed in chip-type to reduce the size and the cost [7]. Besides, the author Huang [8] proposed a voltammetry potentiostat chip with wide signal processing current range from $\pm 12 \mu\text{A}$ to $\pm 12 \text{mA}$.

By means of circuit components off the shelf to realize the low cost (lower than one hundred US dollars) potentiostats on PCB to mimic the commercial ones with lower accuracy (the ADC resolution is 12-bit), the author Huang had devoted to developing several versions of portable potentiostats, for instance, a telemetric system to sense pH and ethanol variation in aqueous solutions [9], a portable amperometric potentiostat for bilirubin biosensor [10], a portable cyclic voltammetry potentiostat to detect the biomarkers of creatinine, urea, and lysozyme correlates with kidney dysfunction [11], and a portable multi-channel potentiostat to measure glucose, EGCG and caffeine concentrations in green tea at the same time [12].

In this paper, taking the advantages of low cost and portability realized by circuit components off the shelf, a low-cost standalone potentiostat is proposed for the signal processing of electrochemical sensors. Unlike the conventional potentiostats using a computer, in the proposed potentiostat, a PDA is used to set the experimental parameters, a mixed-signal microprocessor is used to control the electrochemical experimental process, and an SD memory card is used to store the experimental data. The system power is supplied by a USB charger. Using the proposed potentiostat, the electrochemical measurements of biosensors can be performed outside the laboratory, even in a dangerous environment. In the future, the VMA biosensor can be cooperated with the proposed potentiostat to develop a biosensor for home-care system.

II. IMPLEMENTATION OF PROPOSED POTENTIOSTAT

A. Principle of a potentiostat's operation

A potentiostat is an electronic device used to maintain electrochemical stability in the biosensor and to convert the biosensor's output into an analog signal [13]. A biosensor is composed of a working electrode (W), a reference electrode (R), and a counter electrode (C). The working electrode with the biomolecular probes attached can generate the reaction of the target. Fig. 1(a) is a potentiostat's operation diagram, which can be implemented by the electronic components as

*Corresponding author: cyhun@mail.nutn.edu.tw
DOI : 10.6159/IJSE.2013.(3-2).02



shown in Fig. 1(b). The operational amplifier on the right establishes the control loop to accomplish the potentiostatic control while the integrator on the left converts the current flowing through the W to a voltage for digitization and readout.

B. Design of a standalone potentiostat

Fig. 2 shows the circuit diagram of a standalone potentiostat. The proposed standalone potentiostat is mainly constructed by a mixed-signal microprocessor chip (C8051F005), an auto-range current-to-voltage converter, a unity-gain buffer amplifier, an operational amplifier, a DC-DC power converter, a Bluetooth module, a SD memory card, a USB charger and a personal digital assistant (PDA). We adopt a PDA to set the experimental parameters of the potentiostat and a SD memory card to store the experimental data to replace a PC used in conventional potentiostats. During the process of experiment, the potentiostat is controlled by a microcontroller C8051F005. The power supply is provided by a USB charger, without using AC power supply. This design approach can increase the portability and the ability of standalone operation, and reduce a lot of power consumption because of using a computer.

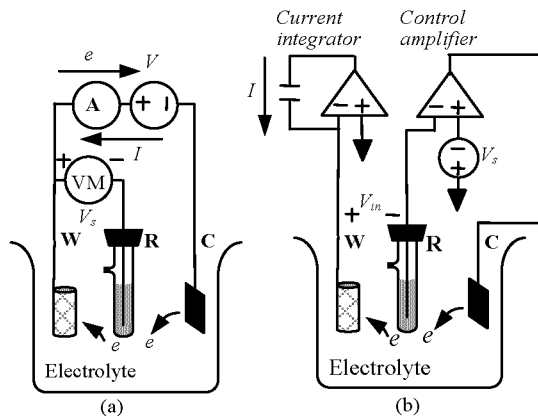

Fig. 1 Potentiostat operation: (a) Concept diagram, (b) Implementation using electronic components.

In the potentiostat, the auto-range current to voltage converter, which contains a transimpedance amplifier and a digital potentiometer, is used to measure the current flowing through the solution between the working and the counter electrodes. It can be used to automatically convert the sensor's current range from ± 12 mA to ± 12 μ A by the microprocessor via adjusting the resistance value of the digital potentiometer.

The C8051F005 chip is an 8051 based CPU with 12-bit digital-to-analog converters (DACs), 12-bit analog-to-digital converters (ADCs), and digital peripherals. According to the specification of C8051F005 chip, the output range of DAC is between 0 and 2.4 V, and hence DAC can generate positive potential only and can't generate negative potential. In order to realize the function of cyclic voltammetry, the potentiostat needs to generate a sweep potential in both forward and reverse directions. Thus, two 12bit DACs (DAC1 and DAC0) are used to generate a scan potential between 0 and 2.4 V, and a 1.2 V offset potential, respectively. The potential of the

working electrode (V_w) is set by the voltage on the operational amplifier's virtual "ground" node as 1.2 V. Based on the preset scan potential, the microprocessor generates a triangular-type signal, and then the DAC1 will transfer it into a triangular-type voltage between 0 and 2.4 V, which is acted as the setting voltage (V_{set}). In the operational amplifier, a negative feedback loop controls the potential of the reference electrode (V_R) to be equal to the setting voltage (V_{set}). According to this approach, the scan voltage V_{WR} will be obtained in the range of -1.2 V to 1.2 V.

The design specifications of the proposed cyclic voltammetry potentiostat are described as follows: the range of the programmable scan potentials (V_{WR}) is between -1.2 V and 1.2 V under the resolution 1 mV, the minimum programmable scan rate is 1 mV/s, and the auto-range of the measured current (I_{WC}) is from from ± 12 mA to ± 12 μ A.

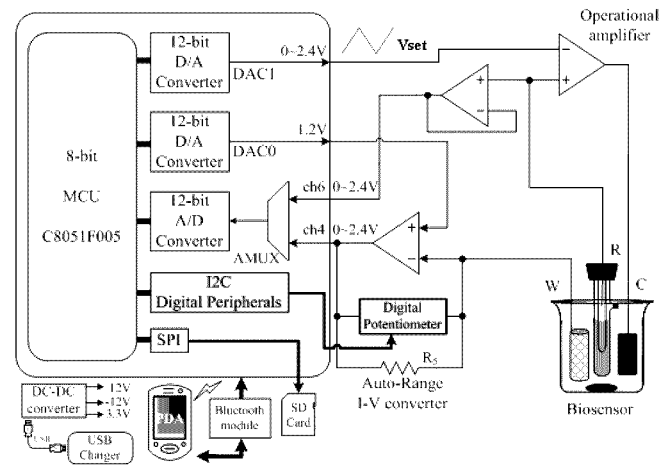

Fig. 2 The circuit diagram of a standalone potentiostat.

C. Auto-range current-to-voltage converter

In the potentiostat, the auto-range current to voltage converter is used to measure the biosensor's current. In the resistance value selection strategy of the digital potentiometer, a sequential search is performed to find a suitable resistor for current-to-voltage conversion. Based on the sequential search algorithm, at first the potentiometer with 100 Ω resistance values is selected, and then the converted voltage will be measured by ch-4 ADC. The measured voltage will be checked whether it is in the range of (1).

$$1.2 - 0.11 < V_{ch7} < 1.2 + 0.11 \quad (1)$$

If the range of converted voltage is in the condition of (1), which means that the presented resistor value is too small to be used, then the resistor values of the potentiometer will be enlarged ten times. The foregoing procedure will be continued until the range of converted voltage satisfies the condition of (2) or until the resistor values reaches 100 k Ω .

$$V_{ch7} < 1.2 - 0.11 \text{ or } V_{ch7} > 1.2 + 0.11 \quad (2)$$

After the suitable resistance is found, the resistance will be recorded and sent to the next cycle current-to-voltage conversion. In the new converting cycle, according to the variation of biosensor current, the previous converting resistor may not suit the present current conversion. So, the converting resistor will be changed to a larger resistance if the condition

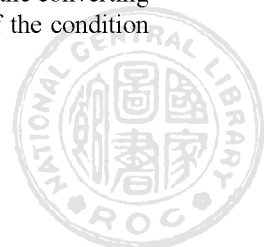

of (1) is satisfied. Or, the converting resistor will be changed to a smaller resistance if the condition of (3) is satisfied.

$$V_{ch7} > 2.3 \text{ or } V_{ch7} < 0.1 \quad (3)$$

D. Personal digital assistant (PDA)

In this paper, we adopt the personal digital assistant (PDA) to control and set up the experimental parameters of the proposed portable potentiostat. Before the experiment of cyclic voltammetry, some experimental parameters have to be set up, such as the range of scan, the scan rate, and the scan cycles. The range of scan can be set by the “initial” and the “final” potentials. The operation interface of the PDA is shown in Fig. 3. This interface is designed by Embedded Visual Basic program. The communication between the PDA and the potentiostat is through a Bluetooth wireless communication. When the experimental parameters are sent to the potentiostat, the potentiostat will perform the electrochemical measurement automatically and then store the measured data in SD memory card.

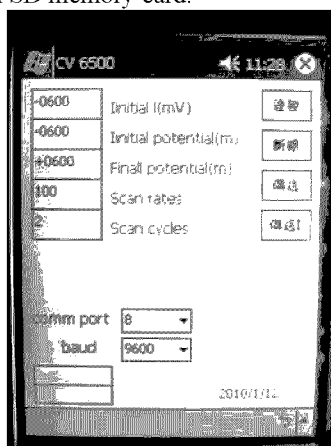

Fig. 3 The operation interface of PDA.

E. SD memory card

The SD memory card is used to store the experimental results of the potentiostat. There are two alternative communication protocols: SD and SPI in memory card system. In order to communicate the memory card with the microcontroller, the SPI communication protocol, which is one of the built-in communication protocols of C8051F005, is used to reduce the design-in effort to minimum. Through the signals of CS, CLK, DataIn, and DataOut, we can connect the SPI interface of C8051F005 with the SD memory card. All communication between the microcontroller and the memory card is controlled by the microcontroller. The FAT16 format is adopted to store data in SD card. The measured data of each experiment will be stored in one text file and can be retrieved to analyze and to plot the experimental diagram by PC.

F. Fabrication of an electrochemical vanillylmandelic acid biosensor

Vanillyl mandelic acid (VMA), an end-stage metabolite of the catecholamines epinephrine and norepinephrine, is produced via intermediary metabolites. The concentration of urinary VMA is usually used to diagnose an adrenal gland tumor called pheochromocytoma, namely a tumor of

catecholamine-secreting chromaffin cells. If a patient's concentration of urinary VMA is high, he may have great opportunity to have such a tumor [14].

In this paper, in order to detect the concentration of urinary VMA, we utilized a three-electrode configuration with working electrode, Ag/AgCl reference electrode, and platinum counter electrode (CE) to construct a VMA biosensor. In the VMA biosensor, the VMA-imprinted polymer with a corresponding shape to the VMA molecules is acted as the sensing element on the working electrode.

The preparation of VMA-imprinted and non-imprinted (NIP) EVAL coated electrode include three steps: (1) spreading 5 μ L of the 44 mole % EVAL solution (EVAL/DMSO=0.1 wt%) mixed with 1 mg/mL of target molecules on the working electrode of a screen-printed electrodes (Dropsens, Spain); (2) solvent evaporation in an oven at 60°C for 9 hours to completely remove DMSO; and (3) removal of the template molecule by rinsing in 20 mL of 1 wt% SDS for 15 mins and then deionized water for 15 mins, repeated three times. All electrodes are immersed and equilibrated with phosphate buffered saline (PBS) overnight before use. In this paper, VMA-imprinted poly (ethylene-co-vinyl alcohol) is coated on a commercial three-electrode screen-printing chip as illustrated in Fig. 4.

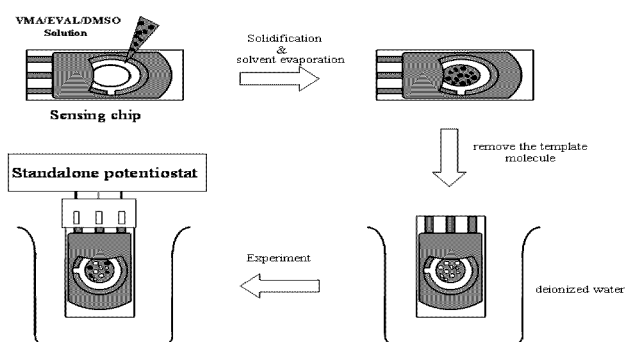
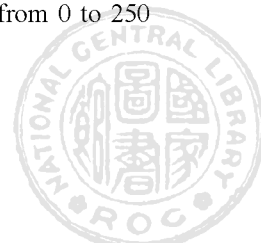

Fig. 4. Preparation of VMA-imprinted EVAL coated working electrode.

III. EXPERIMENTAL RESULTS

Fig. 5 shows a comparison diagram of the cyclic voltammetry measurements performed by the proposed standalone potentiostat and the previous design controlled by a PC [11]. In Fig. 5, the measured results show that the trends in the two different systems are quite close. Fig. 6 is the cyclic voltammograms of the VMA-imprinted biosensor measured by the proposed potentiostat. The cyclic voltammetry measurements for the VMA biosensor are respectively performed in 10 ng/ml, 25 ng/ml, 50 ng/ml, 100 ng/ml, and 250 ng/ml VMA solution, at a scan rate of 100 mV/s, and the scanned voltage is between -0.6 and +0.6V. The profile shows a significant oxidation current around the potential of 46 mV, which implies the feasibility of the electrochemical detection on VMA by the MIP modified electrode. Fig. 7 exhibits the relationship between the target concentration and the current difference, which is re-plotted from Fig. 6. The current response for VMA-imprinted is monotonically increased from 0 to 9.8 μ A, when the VMA concentration is from 0 to 250



ng/ml. According to the variation of the VMA biosensor current, the concentration of VMA can be determined.

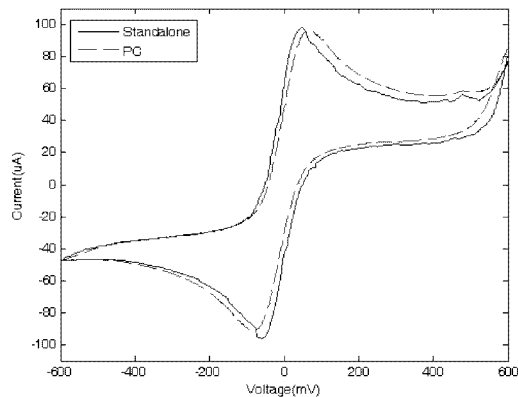

Fig. 5 A comparison diagram of the cyclic voltmetry measurements performed by the proposed standalone potentiostat and the previous design controlled by a PC [11].

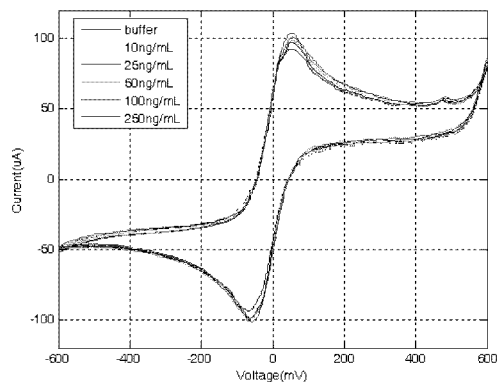

Fig. 6 Cyclic voltammograms of the VMA-imprinted biosensor measured by the proposed potentiostat.

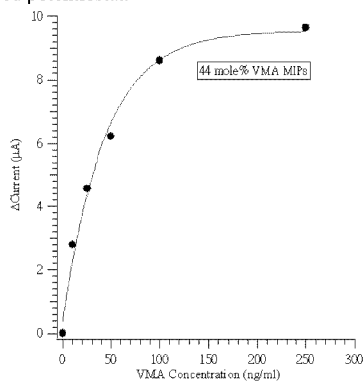

Fig. 7 Current difference for the VMA-imprinted EVAL coated electrode with different concentrations applied.

IV. CONCLUSIONS

In this paper, we propose a low-cost and standalone potentiostat to integrate with the VMA sensing element manufactured by the technique of molecularly imprinting. The experimental results show that the performance of the proposed potentiostat is as good as the commercial ones. In addition, the proposed potentiostat has low cost, low power

consumption, and high portability, which the commercial ones can't compete with. In the future, the VMA biosensor can be cooperated with the proposed potentiostat to develop a biosensor for home-care system.

ACKNOWLEDGMENT

This work was supported by National Science Council of Taiwan under grant numbers NSC 100-2221-E-024 -009, NSC 100-2220-E-006-014, and NSC 101-2221-E-024-027.

REFERENCES

- [1] Gyorffy A., Santha H., "DNA chip with electronically accelerated processes," in *Proceedings of International Spring Seminar on Electronics Technology: Integrated Management of Electronic Materials Production*, pp: 189 – 191, 8-11 May 2003. Doi: 10.1109/ISSE.2003.1260513
- [2] Bandyopadhyay A., Mulliken G., Cauwenberghs G., Thakor N., "VLSI potentiostat array for distributed electrochemical neural recording," in *Proceedings of IEEE International Symposium on Circuits and Systems, 2002. ISCAS 2002*, vol. 2, pp:II-740 - II-743, 26-29 May 2002. Doi: 10.1109/ISCAS.2002.1011459
- [3] McKean B. D., Gough D. A., "A telemetry-instrumentation system for chronically implanted glucose and oxygen sensors," *IEEE Transactions on Biomedical Engineering*, vol. 35, Issue 7, pp: 526 – 532, July 1988. Doi: 10.1109/10.4581
- [4] Glaster H., *pH Measurements-Fundamentals, Methods, Applications, Instruments*, Wiley-VCH, New York. (1991)
- [5] Turner R. B. F., Harrison D. J., and Baltes H. P., "A CMOS Potentiostat for Amperometric Chemical Sensors," *IEEE J. Solid-State Circuits*, vol. SC-22, pp. 473-478, 1987. Doi: 10.1109/JSSC.1987.1052753
- [6] Kakerow R. G., Kappert H., Spiegel E., and Manoli Y., "Low Power Single Chip CMOS Potentiostat," *Transducers 95, Eurosensors IX*, Vol. 1, pp. 142-145, 1995. Doi: 10.1109/SENSOR.1995.717115
- [7] Bandyopadhyay A., Mulliken G., Cauwenberghs G., Thakor N., "VLSI potentiostat array for distributed electrochemical neural recording," in *Proceedings of the 2002 IEEE International Symposium on Circuits and Systems, ISCAS 2002*, vol.2 , pp. 740-743, 26-29 May 2002. Doi: 10.1109/ISCAS.2002.1011459
- [8] Huang C. Y., "Design of a Voltammetry Potentiostat for Biochemical Sensors," *Analog Integrated Circuits and Signal Processing*, Vol. 67, No. 3, 375-381, June 2011. Doi: 10.1007/s10470-010-9569-2
- [9] Liao, W. Y., Lee, Y. G., Huang, C. Y., Lin, H. Y., Weng, Y. C., Chou, T. C., "Telemetric electrochemical sensor," *Biosensors and Bioelectronics*, vol. 20, pp. 482-490, 2004. Doi: 10.1016/j.bios.2004.02.014
- [10] Huang C. Y., Syu M. J., Chang C. H., Chang Y. S., Liu B. D., and Chou T. C., "A portable potentiostat for the bilirubin-specific sensor prepared from molecular imprinting," *Biosensors and Bioelectronics*, vol. 22, pp. 1694-1699, 2007. Doi: 10.1016/j.bios.2006.07.036
- [11] Huang C. Y., Tsai T. C., Thomas J. L., Lee M. H., Liu B. D. and Lin H. Y., "Urinalysis with molecularly imprinted poly(ethylene-co-vinyl alcohol) potentiostat sensors," *Biosensors and Bioelectronics*, Vol. 24, Issue 8, pp.2611-2617, Apr 2009. Doi: 10.1016/j.bios.2009.01.016
- [12] Huang C. Y., Yu-Cheng Huang, and Hung-Yin Lin, "Design of a Portable Multi-Channel Potentiostat for Biomolecule Sensors" *International Journal of Science and Engineering*, Vol.1, No.1, pp. 1-10, 2011.
- [13] Levine P. M., Gong P., Levicky R., and Shepard K. L., "Active CMOS Sensor Array for Electrochemical Biomolecular Detection," *IEEE J. Solid-State Circuits*, vol. 43, pp. 1859-1871, 2008. Doi: 10.1109/JSSC.2008.925407
- [14] Magera M. J., Thompson A. L., Matern D., and Rinaldo P., "Liquid chromatography-tandem mass spectrometry method for the determination of vanillylmandelic acid in urine". *Clin. Chem.* Vol. 49, no. 5 pp. 825–826, May 2003. Doi: 10.1373/49.5.825



BIOGRAPHIES

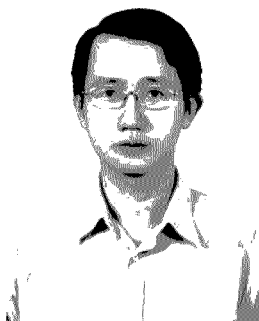

Chun-Yueh Huang was born in Taichung, Taiwan, Republic of China, on March 24, 1967. He received the B.S. degree in industrial education from the National Chang Hwa Normal University, Chang Hwa, Taiwan in 1991, M.S. and Ph.D. degrees both in electrical engineering from the National Cheng Kung University, Tainan, Taiwan, in 1993 and 1997, respectively. Since 2005 he has been on the faculty of the National University of Tainan, where he is currently a Professor in the Department of Electrical Engineering. During 1999–2005, he was an Associate Professor in the

Department of Electronic Engineering of the Kan Shan University. His current researches include signal processing of biosensor, VLSI design, and analog IC design.

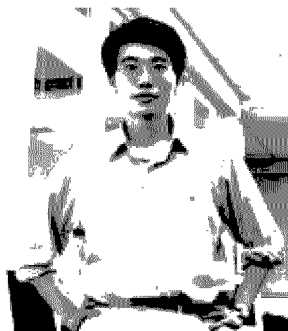

Hung-Yin Lin is a faculty member in the Department of Chemical and Material Engineering and an Adjunct Professor in the Biotechnology Institute at National University of Kaohsiung, Kaohsiung, Taiwan. He received an M.Phil. in 2000 and his Ph. D. in 2003 in Chemical Engineering and Applied Chemistry from the Columbia University in the City of New York. His main research interests include ultrasound drug delivery, synthesis of artificial antibody and biosensors in medical applications.



Wen-Chih Lee was born in Tainan, Taiwan, Republic of China, on January 01, 1987. He received the M.S. degree in Graduate Institute of Electrical Engineering from the National University of Tainan in 2011.